

SEMINAR AGENDA

7:30 a.m.	Registration
8:00 a.m.	Seminar Begins
12:00 to 1:00 p.m.	Lunch (included)
4:30 p.m.	Seminar Ends



SITE VISIT INCLUDED

Seminar includes a visit to an operating pumping station for a hands-on demonstration of pump station maintenance and troubleshooting techniques.



REGISTER TODAY

SPACE IS LIMITED!

- See the enclosed Registration Form for dates, locations, and seminar registration fees.
- To register, please complete the enclosed Registration Form and return with your registration fee.
- Refreshments, lunch and all course materials are included in the seminar registration fee.
- *Preregistration is required. Registrations will not be accepted the day of the seminar.*



QUESTIONS REGARDING THIS SEMINAR SHOULD BE DIRECTED TO:

ENVIREP, INC.
3705 TRINDLE ROAD
CAMP HILL, PA 17011
717-761-7884



WASTEWATER PUMP STATION MAINTENANCE AND TROUBLESHOOTING (ONE DAY TRAINING SEMINAR)



PRESENTED BY:

ENVIREP, INC.
3705 TRINDLE ROAD
CAMP HILL, PA 17011
717-761-7884

WASTEWATER PUMP STATION MAINTENANCE AND TROUBLESHOOTING SEMINAR

SEMINAR OVERVIEW

This one day seminar will present important information for maintenance and troubleshooting of pump stations and centrifugal pumps used for various wastewater pumping applications.

In order to keep pumping equipment running at top performance, it is imperative that operators understand how the equipment operates and how to properly maintain, diagnose and troubleshoot the equipment.



KNOWLEDGE SAVES TIME AND MONEY..... if you have time and resources for only one training experience, make it this one!

SEMINAR TOPICS

- Pump Hydraulic Fundamentals
- Preventative Maintenance
- System Hydraulic Problems and Solutions
- Pump Troubleshooting Techniques
- System and Component Troubleshooting
- Pump Repair Issues
- Safety Concerns
- Using Pump Curves and System Head Curves
- Design Considerations for Ease of Maintenance and Troubleshooting
- Optimizing Pump Performance
- Understanding Control Panels and Level Controls

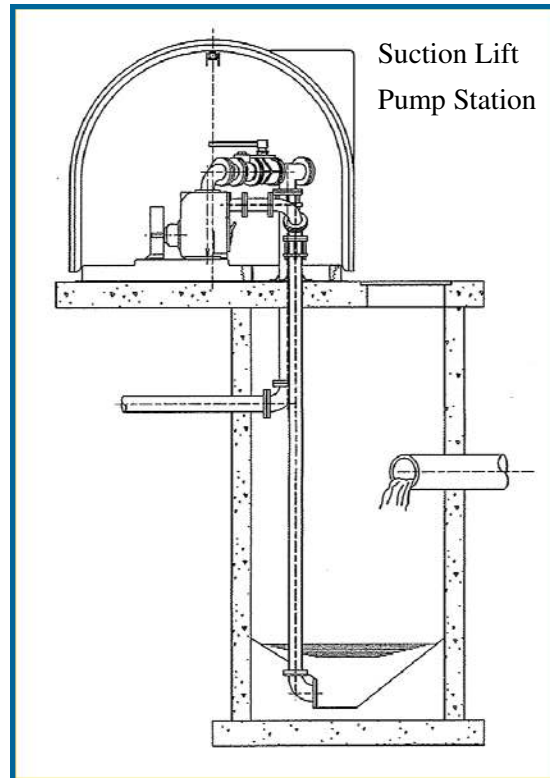

FEATURING GLASS FACED PUMP DEMONSTRATION



WHO SHOULD ATTEND?

- Wastewater treatment plant operators and maintenance personnel
- Engineers interested in learning the basics of pump application and operation

ENHANCE YOUR TRAINING EXPERIENCE

Attend this seminar with a friend or colleague! You can support one another and apply the new skills and techniques you learn to meet your individual and company goals.

CONTINUING EDUCATION CREDITS AVAILABLE

After completion of this seminar, attendees will receive a personalized Certificate of Completion. Seminar is approved for CEU's by the Penna Department of Environmental Protection, MD Department of the Environment and DE Department of Natural Resources.